

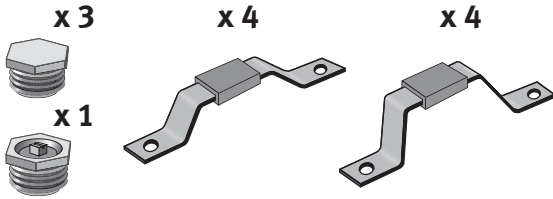

Panel Plus Vertical

Montagehandleiding - Instructions de montage
Montagehinweis - Mounting instructions



Om veiligheidsredenen zijn geen schroeven of muurpluggen meegeleverd.
Contacteer uw specialzaak voor het juiste type.

Pour des raisons de sécurité, les vis et les chevilles ne sont pas fournies. Contactez votre magasin spécialisé pour le bon type de cheville.

Aus Sicherheitsgründen sind keine Schrauben oder Dübel mitgeliefert. Kontaktieren Sie Ihren Baustoffhandel für die richtigen Dübel.

For safety reasons screws or wall plugs aren't delivered. Contact your specialist store for the right type.

Standaard muurbeugels Fixations murales standards Standard Wandbefestigungen Standard wall fixings

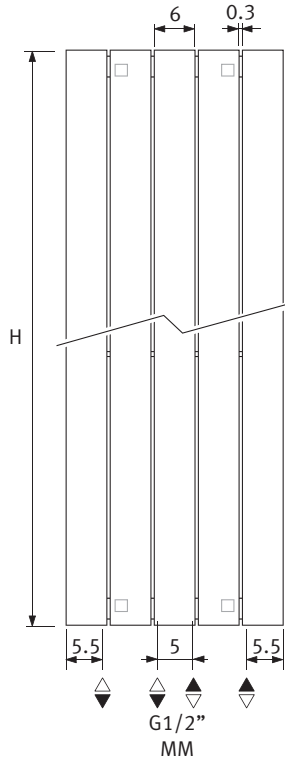
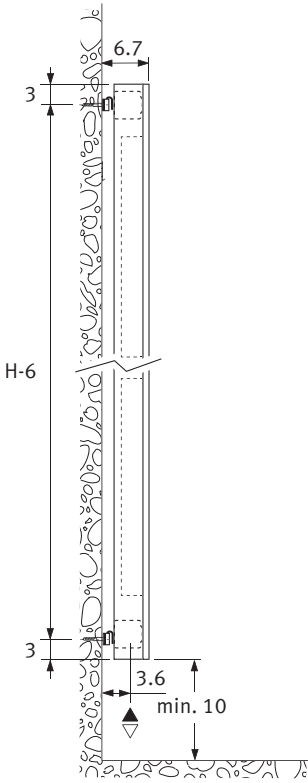
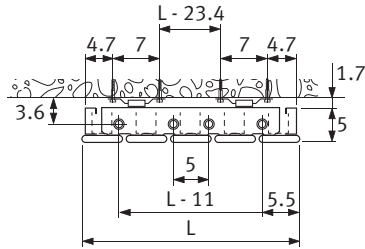
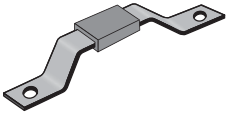

Verlengde muurbeugels Fixations murales rallongées Verlängerte Wandbefestigungen Extended wall fixings

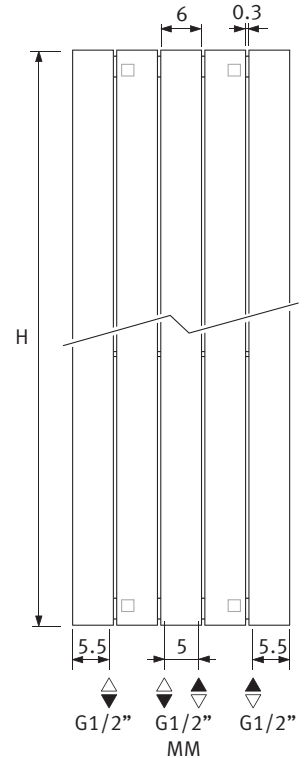
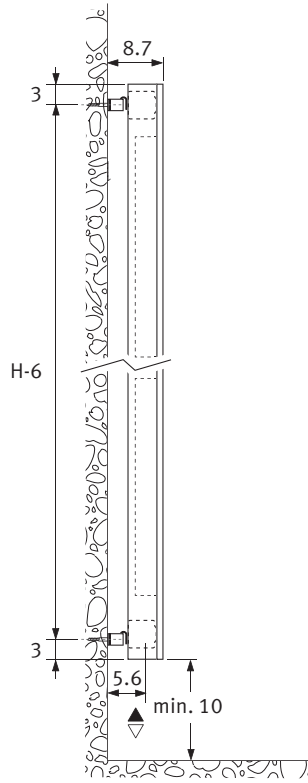
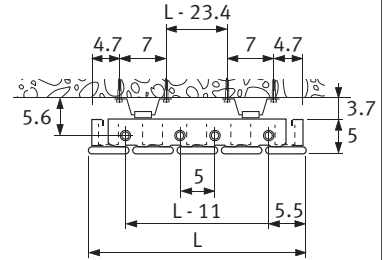
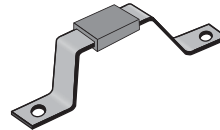

Optie Option

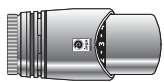

Code 5090.1111



Code 5090.1110

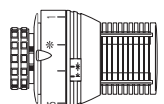

Code 5090.1119



Code 5094.425



Code 5094.427

Code 5090.1111

Standaard Standard

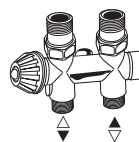
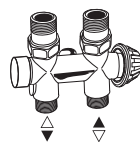

Klemkoppelingen voor ventielen: zie Jaga catalogus.

Raccords bicones pour vannes: voir catalogue Jaga.

Klemringverschraubungen für Ventile:
Siehe Jaga Katalog.

Sleeve couplings for valves: see Jaga catalogue.



Gebruik bij elke hydraulische verbinding
teflon of vlas.

Toujours utiliser du teflon ou du chanvre à chaque
raccordement hydraulique.

Bei jedem hydraulischen Anschluss Dichtband oder
Hanf verwenden.

Always use PTFE tape or flax for all hydraulic
connections.

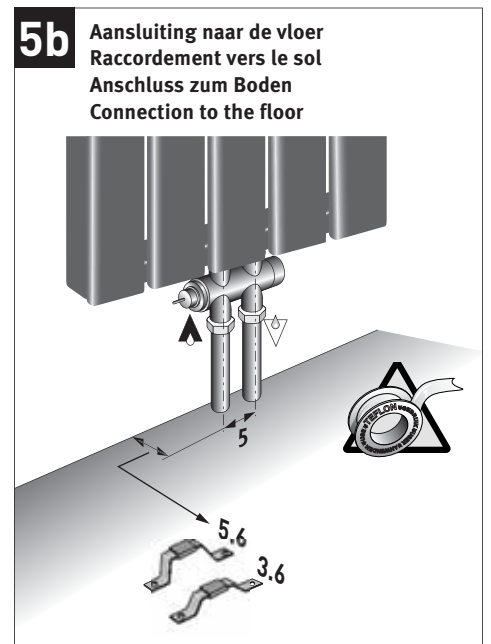
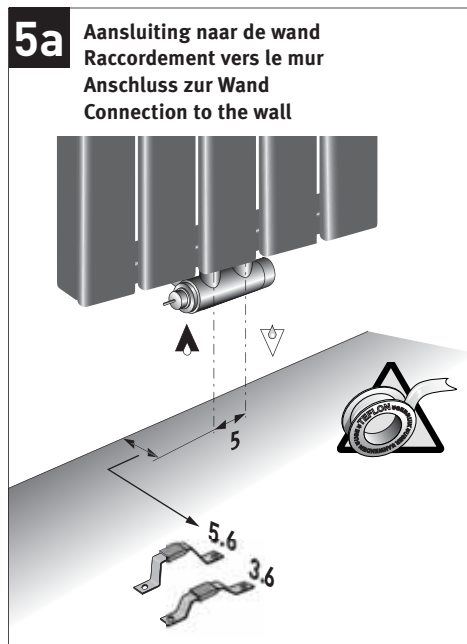
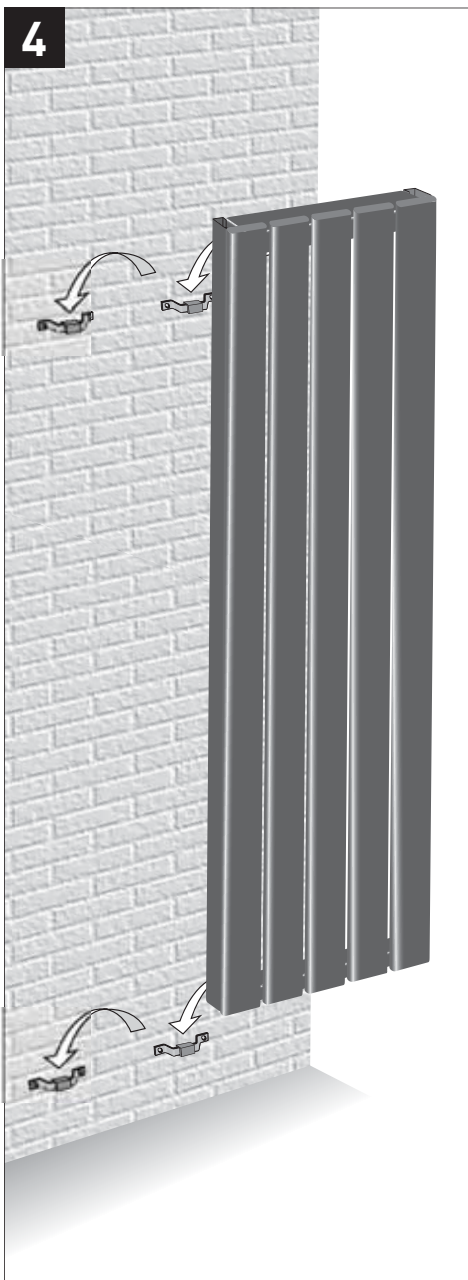
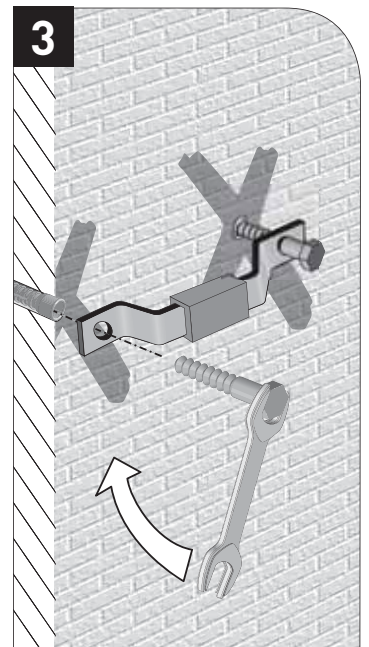
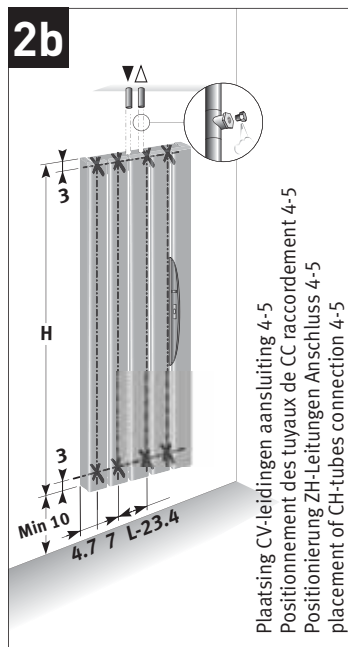
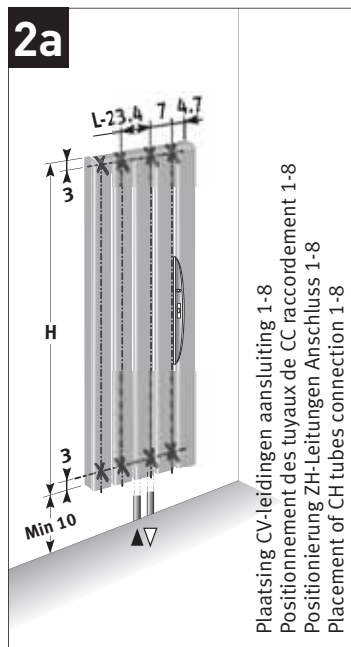
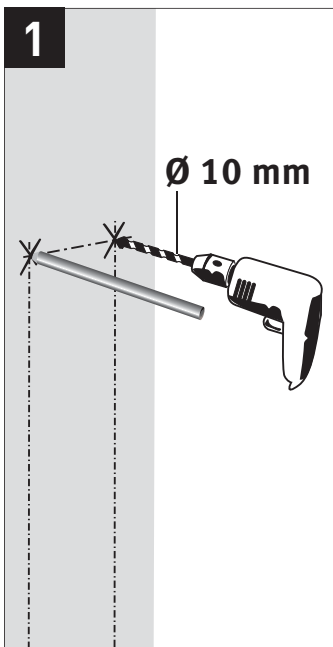

Eenpijp - tweepijpaansluiting
Raccordement monotube - bitube
Einrohr - Zweirohranschluss
One pipe - two pipe connection

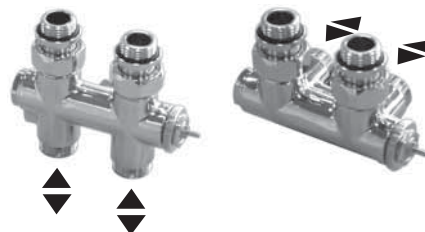

Aanvoer links of rechts, onafhankelijk van positie thermostaatkop.

Arrivée à droite ou à gauche, indépendamment de la position de la tête de vanne thermostatique.

Vorlauf links oder rechts, unabhängig von der Position des Thermostatkopfes.

Flow left or right, independent from the position of the thermostatic head.

